

 <b>Hillrom™</b> Hillrom Luleå Nedre Vägen 100, 975 92 Luleå, Sweden	<b>Field Safety Notice</b>	 <b>FA-2021-11-004-LUL-002</b>
---	----------------------------	--

Date  
Customer Name

**FSCA-identifier:** FA-2021-11-004-LUL-002

**Commercial name of the affected product,**  
Traverse Rail Carrier and Traverse Rail Carrier E-System, wide

**Potentially Impacted devices:**

3101704 TRAV RAIL CARR E-SYST STD	3102514 TR CARRIER SLIM/RAISED, LR
3101705 TRAV RAIL CARR ESYST WIDE	3102517 TR CARR. NORMAL/LOWER. LR
3102506 TR CARRIER WIDE/RAISED ML	3102519 TR CARR. LOW.LR 30MM/PAIR
3102511 TR CARRIER NORMAL, LR	3102531 TRAVERSE RL CARRIER STD/RAISED
3102512 TR CARRIER WIDE, LR	3102532 TRAVERSE RL CARRIER WD/RAISED
3102513 TR CARRIER SLIM, LR	3102562 TR CARRIER, PARALLEL/WIDE

All traverse rail carriers distributed by Hillrom between 04JAN2021 and 24MAR2021 may be affected.

**Type of action:** Field Safety Notice

**To:** Facility Risk Manager/Facility Administrator, Chief Executive Facility Administrator, Facility Engineer, Vigilance Manager, Biomedical Engineering, Medical Device Liaison Officer

**Description of the problem:**

Hillrom has received reports where the Hillrom Service Technician installing the traverse rail carriage found that it had been delivered with non-conforming screws, that are too short to ensure appropriate installation. Should the system be installed with the non-conforming screws, there is a potential that the screws are unable to secure the traverse rail appropriately and could loosen over time causing the rail system to fall, potentially causing a safety risk to caregivers and/or patients.

**Background:**

A traverse system consists of two primary rails with a secondary rail in-between. See figure 1 below.



Hillrom™

Hillrom Luleå Nedre Vägen 100, 975  
92 Luleå, Sweden

## Field Safety Notice

**Baxter**

FA-2021-11-004-LUL-002

Figure 1

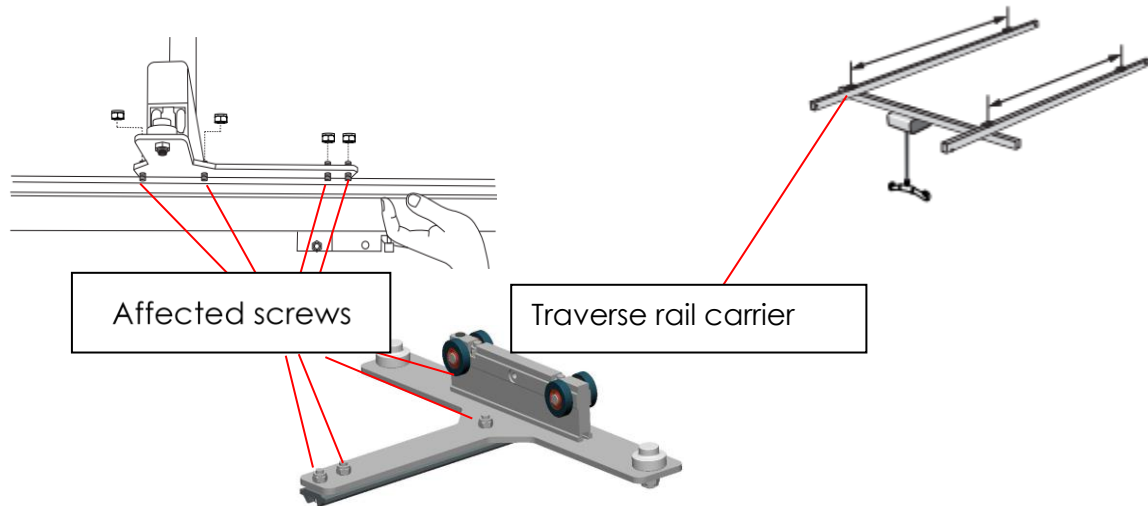

Hillrom received an out of box complaint where it was discovered that the traverse carrier had been delivered with the incorrect, non-conforming screws. The length of the screws according to specification is M8X25 (25 mm) whilst the screws of the affected batch were M8X20 (20 mm). M8X20 does not lock against the nyloc nut when installed per the installation instructions, as per figure 2 (correct screw) and figure 3 (incorrect screw) below.



Figure 2 - conforming



Figure 3 - non-conforming

### Potential Risk:

Should the system be installed with non-conforming short screws and fail, there is potential for a patient and/or caregiver to be hit by falling objects or dropped from the lift, causing a potentially catastrophic injury.

There is no post market evidence of the rail carrier being installed with these short screws and Hillrom has not received any complaints of system failures, patient, or caregiver harm.

 <b>Hillrom™</b> Hillrom Luleå Nedre Vägen 100, 975 92 Luleå, Sweden	<b>Field Safety Notice</b>	 <b>FA-2021-11-004-LUL-002</b>
---	----------------------------	--

**Actions to be taken by Customer:**

Please identify if you have the potentially affected product in your facility (See affected device listing above). Do not use your traverse carrier until inspected by a Hillrom Technician. Return the response form below within two weeks. Upon receipt of the response form, Hillrom will contact you to schedule a visit to inspect your carriers. Should incorrect, non-conforming screws be present, these will be exchanged by an approved Hillrom technician.

**Action to be taken by the Distributor:**

Please share this Field Safety Notice with your end users and complete the attached response form and return to [hillromLUL002OUS@sedgwick.com](mailto:hillromLUL002OUS@sedgwick.com) within two weeks. Hillrom will provide replacement screws for Distributors to facilitate exchange among your end users.

**Action to be taken by Hillrom:**

Hillrom will arrange a site visit to inspect the potentially affected units. If short screws are identified, they will be exchanged with those of correct length.

**Contact Reference Person:**

Should you have any questions regarding this Field Safety Notice and field corrective action, please contact Hillrom Technical Support, using email or number below.

Market /Region/ Country	Phone Number	Technical Support Email
Austria	(+ 43) 2 243 285 50	service.dach@hillrom.com
Germany	(+ 49) 2 0149869500	service.dach@hillrom.com
Switzerland	(+ 41) 8 48 811530	service.dach@hillrom.com
Spain	(+ 34) 9 36856000	asistencia@hillrom.com
Italy	(+ 39) 02 950541	assistenza.technica@hillrom.com
France	(+ 33) 0 820 012345	sav@hillrom.com
Sweden	(+ 46) 20-781030	ordernordic@hillrom.com
UK/Ireland	(+ 44) 1530 562176	UKTechSupport@hillrom.com
Netherlands	Contact your Local Hillrom Distributor	
Eastern Europe Countries	Contact your Local Hillrom Distributor	
Middle East & Africa	Contact your Local Hillrom Distributor	
India Sub-Continent	Contact your Local Hillrom Distributor	

 <b>Hillrom™</b> Hillrom Luleå Nedre Vägen 100, 975 92 Luleå, Sweden	<b>Field Safety Notice</b>	 <b>FA-2021-11-004-LUL-002</b>
---	----------------------------	--

**Transmission of this Field Safety Notice:**

Please ensure this notice is circulated to all appropriate personnel. This may include, but is not limited to:

A&E departments	In-house maintenance staff
Adult intensive care units	IV nurse specialists
All wards & Clinics	Medical directors
Biomedical engineering staff	Nursing executive directors
Clinical governance leads	Oncology units
Day case theatres	Pediatric intensive care units
EBME departments	Risk managers
Equipment stores & Libraries	Supplies managers
Health and safety managers	Theatres

The undersign confirms that this notice has been communicated with the appropriate Regulatory Agency.

Sincerely

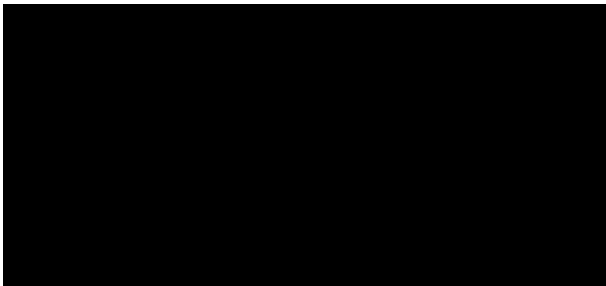



Hillrom™

Hillrom Luleå Nedre Vägen 100, 975  
92 Luleå, Sweden

## Field Safety Notice

**Baxter**

FA-2021-11-004-LUL-002

# Response Form / Receipt Sample

**Subject: Traverse Rail Carrier and Traverse Rail Carrier E-System, wide  
(FA-2021-11-004-LUL-002)**

**It is important** that you return this form/receipt as acknowledgement of your receipt and provide us with the necessary information.

Please complete the following with the correct information and **return this Response Form within two weeks**. Upon receipt of this Response Form, Hillrom will arrange a site visit to exchange the short screws with those of correct length. See return instructions at bottom of page.  
Thank you!

Hillrom account number (if known): \_\_\_\_\_

Name of the facility: \_\_\_\_\_

Address of the facility: \_\_\_\_\_

City: \_\_\_\_\_ Zip: \_\_\_\_\_ Country: \_\_\_\_\_

Facility Contact Person Name: (print)  
\_\_\_\_\_

Signature: \_\_\_\_\_ Date: \_\_\_\_/\_\_\_\_/\_\_\_\_

Title: \_\_\_\_\_ Phone: \_\_\_\_\_

Email: \_\_\_\_\_

### Check actions taken:

We have reviewed and understand the attached Field Safety Notice.

Yes  No

Results from the inspection of our product show:

- We **do not** have any impacted devices per page 1.
- We need Hillrom to inspect our potentially impacted devices as per page 1.

Quantity: \_\_\_\_\_

### Distributors only:

- We have distributed the product further and notified our consumers of the attached Field Corrective Action per the instructions noted above.
- We will support our end users in correcting any non-conforming short screws installed
- We require replacement screw kits for \_\_\_\_\_ devices (provide quantity needed)

Response form shall be returned to [hillromLUL002OUS@sedgwick.com](mailto:hillromLUL002OUS@sedgwick.com) within two weeks from receipt